

# REINFORCE

JOURNAL OF THE BRITISH ASSOCIATION OF REINFORCEMENT

2021

**New research  
proves concrete's  
cost benefits**

**Concrete  
future proofing  
warehouse  
construction**

**Eco champions**

**Members' news  
and views**

**Reinforced trust**



[www.uk-bar.org](http://www.uk-bar.org)



# RAISE THE BAR

FOR REINFORCED SUCCESS  
CHOOSE A MEMBER OF  
THE BRITISH ASSOCIATION  
OF REINFORCEMENT



- CARES APPROVED
- COMMITTED TO HEALTH AND SAFETY
- RAISING STANDARDS
- COMMITTED TO SUSTAINABILITY
- RESPONSIBLY SOURCED
- DELIVERING QUALITY AND ADDED VALUE
- PRODUCT INNOVATION AND PROCESS DEVELOPMENT



BAR MEMBERS: GIVING YOUR PROJECT A REINFORCED ADVANTAGE

[www.uk-bar.org](http://www.uk-bar.org)

# Contents

- 3 Welcome
- 4 BAR seminar explains how to reduce CO<sub>2</sub> emissions and costs
- 5 BAR welcomes UK Carbon Budget inclusion of shipping emissions  
Membership 'win-win' for BAR and CONSTRUCT
- 6 ECO champions  
The new warehouse: concrete benefits
- 7 ArcelorMittal fulfilling its responsibilities
- 8 Tideway success for CELSA
- 9 Making the connection
- 10 Research confirms reinforced concrete constructions offers best total price
- 13 The labour and materials crisis: the contractor perspective
- 15 Pressing ahead at Hinkley Point C
- 16 An nVentful performance
- 17 Leading the way for customer service
- 18 Reinforced trust
- 19 BAR members directory

# REINFORCE

## 2021

## Welcome

Welcome to Reinforce 2021, the annual journal of the British Association of Reinforcement.

This issue demonstrates how, via a continued focus on collaboration and efficiency plus a willingness to explore new ways of addressing challenges, the reinforcement sector continues to move forward to reduce its environmental impact and increase the potential of project cost savings.

The success of this focus was underlined by the recent BAR seminar that was presented by the industry for the industry. Delegates learnt about the innovations to reduce the carbon emissions of steel reinforcement manufacture. They were also presented with new, never done before, research that proves that concrete with all its free performance benefits offers unrivalled reduced whole life costs. Indeed, the research explained that when comparing the costs of additional finishes necessary for a building's operational performance, reinforced concrete with its wide range of inherent benefits can be up to 30% cheaper than rival construction materials. The seminar also provided another first – the introduction of a new UK reinforcement certification scheme.

It is also underlined by the ongoing determination of BAR members to 'raise the bar'. This has seen three fabricator members, BRC Reinforcement, Express Reinforcement and ROM Group, all being awarded an 'Excellent' rating in their latest Eco-Reinforcement Certification and developing a new customer portal to deliver increased customer service. Meanwhile, manufacturer member ArcelorMittal is underlining its determination to increase its environmental credentials by moving towards using electricity from renewable sources only and has launched its XCarb™ initiative. Not to be outdone, the reinforcement accessories members of BAR continue to provide ongoing product development and enhancement.

Increased industry collaboration will result from the new reciprocal membership arrangement between BAR and CONSTRUCT – the concrete structures group. Dialogue and exchange of expertise and experience between reinforcement fabricator and concrete contractor will benefit the reinforced concrete industry as a whole.

The construction industry is a challenging one. BAR and its members, as this Reinforce issue shows, are determined to turn those challenges into opportunities.

Stephen Elliott

Chairman of the British Association of Reinforcement

The British Association of Reinforcement [BAR] is the industry association for UK Manufacturers and fabricators of steel reinforcement products including cut-and-bent and mesh.

BAR aims to add value to the reinforcement industry via market and product development, the promotion of health and safety as well as social value and environmental best practice and providing a forum to help forward the reinforced concrete industry as a whole.

T: 07802 747031 | E: [condialogue@aol.com](mailto:condialogue@aol.com) | W: [uk-bar.org](http://uk-bar.org)

# BAR SEMINAR EXPLAINS HOW TO **REDUCE CO<sub>2</sub> EMISSIONS AND COSTS**

The recent BAR industry seminar explained how increased efficiency coupled with the vision to examine new ways working can help reduce steel reinforcement carbon emissions and costs. Key to this are a number of steel reinforcement initiatives and developments.

The seminar began with a review of the new research carried out by the University Greenwich that analysed and compared the additional costs necessary for steel and timber to offer the equivalent performance benefits that are free and inherent with concrete construction. Dr George Agyekum-Mensah, University of Greenwich, explained how true cost comparison details of construction materials are scarce. Previous studies on cost analysis are mainly focused on the independent cost of construction without critical comparisons and without considering the performance benefits. He concluded that the additional costs for finishes and the savings made possible due to inherent benefits of concrete should be included as part of total construction cost comparisons. CO<sub>2</sub> and cost savings were central to the presentation from Jamie Holling of BRC Ltd who outlined the savings in time, waste and CO<sub>2</sub> that can be made through early engagement and collaboration with your reinforcing steel supplier at the early stage.

The developments and ongoing improvements being instigated by reinforcement manufacturers to reduce associated carbon emissions were then discussed. Dave Sheedy of ArcelorMittal presented on Net zero 2050 and ArcelorMittal's XCarb programme. He explained how the xCarb programme is reducing the level of CO<sub>2</sub> emissions associated CO<sub>2</sub> emissions during the fabrication process of reinforcement. In particular, he highlighted the technology investment being made to achieve carbon net zero, the introduction of green steel certificates and the range of green steels and their manufacture methodologies. Joseph Poole of CELSA, examined the overall benefits of specifying UK produced reinforcing steel with a particular focus on the potential carbon savings. He examined the full life-cycle of reinforcement and how digitalization tools can help with making more informed purchasing decisions.

The increased focus by the reinforcement sector on collaboration and efficiency has prompted the British Board of Agrément (BBA) to develop a new scheme aimed at forwarding the progression and quality of reinforcing steel products. Professor Bill Hewlett explained how BBA has spent much of 2021 listening to and talking with the market to understand where it can provide additional value through service offerings that support time and cost-saving via increased efficiency. As a result, the BBA has developed a Steel Reinforcing Scheme that offers users the ability to streamline their businesses, use recognised credentials already achieved, and build on a future of product and system quality and compliance.

This was an informative seminar presented by the industry for the industry. It shared good practice, industry viewpoints and new ideas. All of which will help forward the reinforcement sector.



# BAR WELCOMES UK CARBON BUDGET INCLUSION OF SHIPPING EMISSIONS

BAR has welcomed the Government's decision that the next UK's Carbon Budget will, for the first time, include the UK's share of international aviation and shipping emissions.

The Carbon Budget will set in law a target to reduce CO<sub>2</sub> emissions by 78% by 2035 compared to 1990 levels. It will limit the volume of greenhouse gases (GHG) emitted over a five-year period from 2033 to 2037 and so ensure Britain remains on track to end its contribution to climate change while remaining consistent with the Paris Agreement. The inclusion of shipping emissions will underline the environmental impact of importing construction materials and will question the environmental credentials of timber and steel which are often imported from thousands of miles away.

Some 95% of UK concrete is produced in the UK and the supply of reinforcement, manufactured using 98% recycled scrap metal, has short, local supply chains. By comparison, 67% of timber and 60% of structural steel is imported from as far afield as Canada, the Middle East and China.

UK carbon budget targets cannot be met by importing materials and goods that have significant CO<sub>2</sub> shipping carbon emissions. Specifiers of construction materials will have to look beyond spurious green claims to the carbon realities of long-distance shipping.

BAR member steel reinforcement is produced via the Electric Arc Furnace (EAF) method. This has a reduced carbon footprint of nearly four times when compared to the Basic Oxygen Steelmaking (BOS) process. All BAR members have ongoing objectives and programmes to reduce the environmental impacts of their operating processes.

## MEMBERSHIP 'WIN-WIN' FOR BAR AND CONSTRUCT

BAR is delighted to announce a reciprocal industry associate membership agreement with CONSTRUCT – the concrete structures group.

Membership of each other's organisations will benefit the member companies of both industry bodies and help to forward the reinforced concrete sector as a whole. Welcoming the membership agreement, Steve Elliott, BAR Chairman, said: "BAR's membership of CONSTRUCT and CONSTRUCT's membership of BAR will help forward industry collaboration particularly in the areas of health and safety, environmental and industry best practice. Its a win-win for both organisations. We look forward to increased levels of industry collaboration."

In response, Neil Marney, CONSTRUCT Chairman, said: "CONSTRUCT is committed to working closely with the wider industry to bring about positive and meaningful change that improves the environment for companies and their workforce. This is why it is fantastic that we can now work more closely with BAR to make the industry safer, sustainable, and productive to the benefit of both our memberships."





# CHAMPIONS

Three BAR members, BRC Reinforcement, Express Reinforcement and ROM Group, have all achieved an 'Excellent' rating in their latest Eco-Reinforcement Certification. This is a significant achievement and recognises each businesses' commitment to continuing to 'raise the bar' in relation to their responsible sourcing practices.



Eco-Reinforcement, the Responsible Sourcing Standard for Reinforcing Steel, has recently been updated to version 3 in order to make the standard more rigorous and challenge status quo within the industry.

Commenting on their achievement, Eco-Reinforcement Director Jamie Holling said: "Achieving an excellent rating in Eco Reinforcement version 3 represents an outstanding effort from all three member companies. This achievement demonstrates a fully focused commitment to responsible sourcing and stakeholder engagement."

Each business has gone beyond what is required of them, and in some cases has surpassed the scheme's new requirements.

Commenting on the audit process Daniel Speakman, Environmental Coordinator, said:

"The process of being audited to the rigorous new version 3.0 of the Eco Reinforcement Standard was challenging but thoroughly rewarding and exhibited just how much progress has been made. We have worked especially hard in the last 12 months on aspects of our public sustainability reporting, internal training and engagement with our supply chain on circular economy solutions which have contributed to our 'Excellent' rating. The audit results are valuable to showcase our achievements and we will by no means pause our efforts for continual improvement."

For more information on Eco-Reinforcement and the scheme requirements, contact: [enquiries@eco-reinforcement.org](mailto:enquiries@eco-reinforcement.org)

## THE NEW WAREHOUSE: CONCRETE BENEFITS

BAR has published a new report asking why the demand for new smart warehouses is being met by the ubiquitous tin shed when there is a better solution.

'The New Warehouse: Concrete Benefits' outlines a new generation of warehouses and logistic centres that is being driven by the increased use of automation, barcode and RFID/smart tag technology, higher lift trucks and value-added processes. It argues that the new warehouse has to be more functional, more efficient and more accessible. It needs to meet sustainability and climate resilience expectations. It needs to be able to adapt to future requirements.

This calls for a construction solution that is more sophisticated than the ubiquitous tin shed.

Heavyweight concrete construction offers a real alternative to run-off-the-mill lightweight constructed warehouses and logistic centres. It provides inherent fire resistance, enhanced thermal efficiency, robust security, flooding resilience and sustainability. In addition, heavyweight concrete is better for meeting the changing demands of the evolving warehouse and logistics sector. These free, built-in, concrete benefits provide a construction solution that is better suited to meet the growing demand for higher-value, automated warehouses.



The New Warehouse: Concrete Benefits' can be downloaded at: <https://bit.ly/3f6dO8J>



# ARCELORMITTAL

## FULFILLING ITS RESPONSIBILITIES

Reflection is often the precursor to recognition and then progression. This is certainly true for the team at ArcelorMittal Kent Wire Ltd and ArcelorMittal Construction Solutions who continue forward sustainability and social value.

Developments to ensure ongoing reduced environmental impacts include moving to using electricity from renewable sources only, which has resulted in a saving of over 1500 t/CO<sub>2</sub>e. To prove their commitment even further, the company now use a waste management company that ensures zero waste goes to landfill. At corporate level ArcelorMittal

has launched its XCarb™ initiative. XCarb™ is designed to bring together all of ArcelorMittal's reduced, low and zero-carbon products and steelmaking activities, as well as wider initiatives and green innovation



projects, into a single effort focused on achieving demonstrable progress towards carbon neutral steel.

ArcelorMittal believe that steel has a critical role to play in helping society decarbonise and will very much be a solution to the problem. With this in mind, the company believes that it has a significant responsibility to innovate, implement and navigate a successful pathway towards a cleaner steelmaking industry. Its journey towards becoming carbon neutral by 2050, having aligned with the Paris climate goals and the European Green Deal by committing to reduce European CO<sub>2</sub> emissions by 35% by 2030 and be carbon neutral by 2050, is well underway.

ArcelorMittal Kent Wire Ltd and ArcelorMittal Construction Solutions are following that corporate lead to the level that the additional CO<sub>2</sub> emissions from transporting the materials to site and ongoing operations account for less than 6% of the total CO<sub>2</sub> emissions of the finished product which include those resulting from the steel making.

As part of its drive to deliver social value. Senior members of the business management team are mentoring students at the nearby Medway Campus of the University of Greenwich. This project has been going on for a few years and the last 12 months has seen 4 of the mentees employed by the business in areas from sustainability to design. What is even more important to the future of the industry is that these staff are all female thereby forwarding the promotion of women in engineering.



# TIDEWAY SUCCESS FOR **CELSA**

CELSA Steel UK continues to cement itself as a key player within the UK infrastructure sector as it becomes a key supplier to the Thames Tideway Tunnel, the largest infrastructure project ever undertaken by the UK water industry.

This £745m project is essential in helping to tackle overflows from London's Victorian sewers into the Thames for at least the next 100 years. The new sewer tunnel will be over 12.7km long and will help reduce sewage-related waste by 90%.

CELSA Steel UK have been working alongside their downstream businesses to supply over 14,000 tonnes of reinforcing steel to this historic project. As a result, all of the reinforcing material supplied will be 100% UK sourced and will have a 98% recycled content. Coupled with these credentials, the material will also be certified to the responsible sourcing standard for reinforcing steel, Eco-Reinforcement.

CELSA are strategically placed to help minimize the overall carbon emissions associated with this project, as all of the reinforcing steel supplied will travel less than 200 miles from mill to construction site.

The Thames Tideway Central Station project will create over 4,000 sustainable jobs and another 5,000 indirectly. It will also offer hundreds of local apprenticeships and work placements, leaving a lasting legacy in the heart of London.

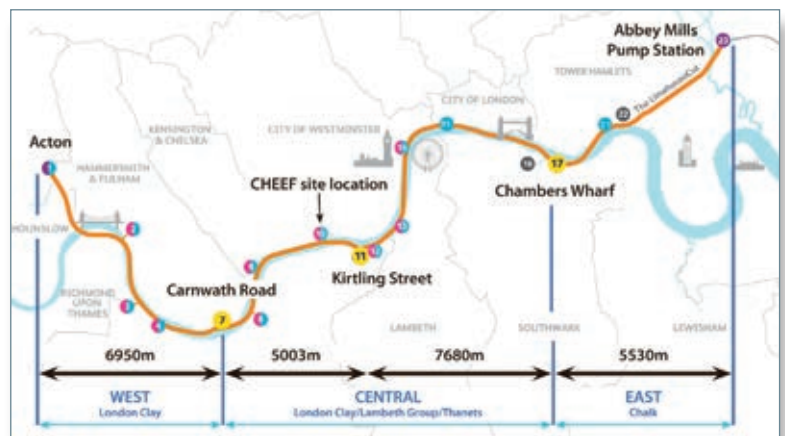

*Thames Tideway Central Section*





# MAKING THE CONNECTION

In exclusive partnership with SFB, RFA-Tech are now the sole distributor for the Geoconnect Shear Dowel Connector to the UK construction market. The Geoconnect Shear Dowel Connector is easy to install as well as being a cost-effective alternative to the more traditional methods of construction. This CE marked product is designed to carry large loads across expansion and contraction joints in concrete structures safely and efficiently.

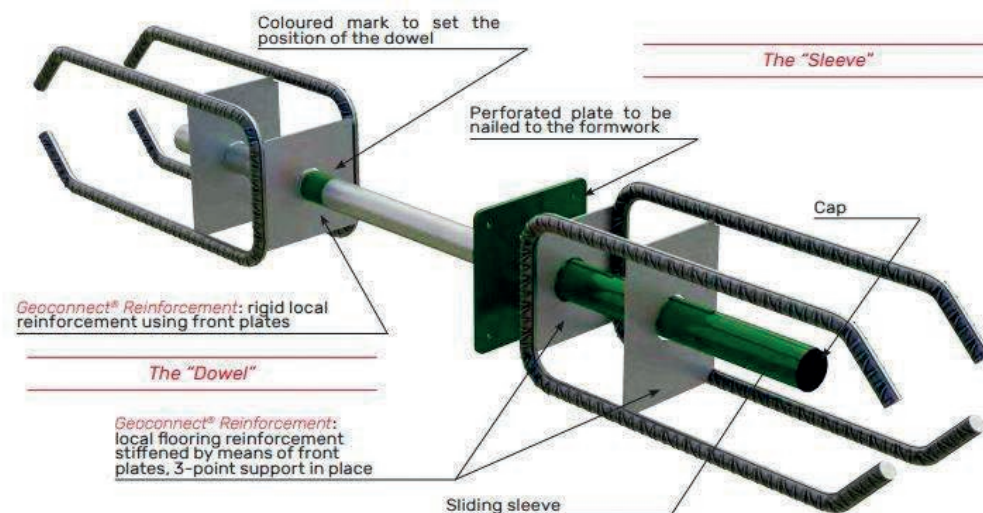

Geoconnect Shear Dowel Connector comprises of two locally welded reinforced pieces, a dowel bar and sleeve to allow movement on both sides of the construction joint. The sleeve is available in single and double options which allows both longitudinal and lateral movement to be accommodated. Available in five diameters, the Geoconnect Shear Dowel Connector is a vital addition to an engineer's design option being compatible with a range of concrete strengths, expansion/contraction joints, widths and floor thicknesses.

The Geoconnect Shear Dowel Connector has excellent mechanical properties and has a high resistance to corrosion and is available in both Stainless Steel and Mild Steel HDG. The Geoconnect carries ETA 16/0064 Approval [CE marking] and has been awarded a DAU [Document of Assessment for fitness of Use] for transferring shear loads.

The potential of the connector system was realized on the Battersea Power Station Phase III project. Working along with the design engineers and site team, a design was provided for a shear connection system that allowed double movement along the construction joints. The site team found the product easy to install and was a cost effective solution comparable to other similar products within the market place. The product was used by the same contractor on an earlier phase and they've continued to enjoy the benefits of using the Geoconnect Shear Dowel system.

The Geoconnect Shear Dowel Connector is fully supported by an engineering department, with design software downloadable from the RFA-Tech website [www.rfa-tech.co.uk](http://www.rfa-tech.co.uk). The software is easy to use and gives engineers confidence of a usable design that can transition to site.

# RESEARCH CONFIRMS REINFORCED CONCRETE CONSTRUCTION OFFERS **BEST TOTAL PRICE**

New research has found that, when comparing the costs of additional finishes necessary for a building’s operational performance, reinforced concrete with its wide range of inherent benefits can be up to 30% cheaper than rival construction materials.

The research, ‘Critical analysis of building performances and cost comparison of reinforced concrete, steel and timber framed building’ was undertaken by the University of Greenwich. It is unusual in that whilst there have been a number of cost comparison studies comparing the costs of actual construction, these do not examine the costs of the additional finishes for occupational performance. There is much anecdotal evidence of the inherent benefits of reinforced concrete – for example: fire resistance, flood resilience, sound insulation – but no specific studies of the extra cost of the additional finishes necessary for steel and timber construction to offer the equivalent performance.

With this in mind, the British Association of Reinforcement invited the University of Greenwich to undertake independent research to determine and quantify if the supposed inherent benefits of reinforced concrete translate into real cost advantages over steel and timber.

The research focused on eight critical additional performance costs: acoustic insulation; fire protection; thermal insulation; insurances; vibration performance; energy efficiency; maintenance; robustness. It found that for reinforced concrete the cost was either zero or low.

Performance cost factors			
Factors	Concrete framed	Steel framed	Timber framed
Acoustic insulation	No <sup>1</sup>	Yes <sup>2</sup>	Yes
Fire protection	No	Yes	Yes
Thermal insulation	No	Yes	Yes
Insurances	Low	Medium	High
Vibration performance	No	No	Yes
Energy efficiency	No	Yes	Yes
Maintenance	Low	Medium	High
Robustness	Low	Medium	High

1: No means no additional cost  
2: Yes means additional cost





Acoustic and thermal insulation play a major role in occupant comfort. Concrete construction is known for providing excellent levels of acoustic and thermal mass at no extra cost. In terms of fire protection, concrete is inherently fire resistant and offers up to 4 hours free fire protection. Steel although is inherently non-combustible can lose much of its structural strength when heated to extreme temperatures and timber requires considerable additional fire protection in order to provide equivalent fire resistance. Timber also provides less robustness when compared with concrete and steel and can result in high on-going maintenance costs resulting from flood damage or fungal and insect attack. The range of inherent performance benefits means that concrete buildings are often cheaper to insure. Indeed, the research quote a 2017 study carried out by VanderWerf and Haidari that found commercial property insurance can be 40% cheaper for concrete buildings whilst builder's risk insurance is some 47% cheaper.

The research consists of 4 stages: systematic review; documentary analysis; systematic cost analysis and final synthesis.

The systematic review included a critical review and performance cost analysis of the reinforced concrete, steel and timber construction. This resulted in a number of comparative tables which enabled documentary analysis to be carried out on an identical building using the different construction materials. The overall building costs per metre square was estimated for each option. This led to the third stage of the research which focused on cost analysis using the Royal Institution of Chartered Surveyors [RICS] Building Cost Information Service [BCIS]. BCIS is a cost data-based system that collates past project analyses of UK projects. It also provides data to enable cost forecasting and cost planning. The research used BCIS to establish the frequency use of concrete, steel and timber-framed construction for five main categories of buildings and then carry out an analysis of

the average cost of m<sup>2</sup>. Local factors and tender price index adjustments were considered to ensure a fair comparison. This included a further analysis to simulate if the projects had been built in December 2020 [4Q 2020].

The final stage of the process was to provide a synthesis of the previous 3 stages to allow a final comparison of average cost per m<sup>2</sup>. This found that when taking account of the additional cost of performance finishes, concrete frame construction was some 31% cheaper than steel frame construction. See the table below:

Summary of average cost for per m <sup>2</sup>			
Construction type	Existing cost	Adjusted [4Q 2020] data	Percentage drift
Concrete framed	£1,782.54	£2,039.94	-31%
Timber framed	£2,149.33	£2,375.09	-20%
Steel framed	£3,355.00	£2,977/19	0%

The study by Greenwich University is arguably the first that provides a detailed cost comparative analysis and discussion of the performance benefits of different construction materials that can reduce both building construction and ongoing costs. It recognises the range of free benefits of concrete construction and underlines the need to fully consider the additional performance costs of other construction materials when determining the real overall cost of a building's construction.

To download a copy of 'Critical analysis of building performance benefits and cost comparison of reinforced concrete, steel and timber framed building' visit: <https://bit.ly/3CyqTCE>

GIVE YOUR PROJECT A REINFORCED ADVANTAGE

# REINFORCED CONCRETE CONSTRUCTION LOOKS AFTER YOUR WALLET



## AT NO EXTRA COST.

THERMAL EFFICIENCY, FIRE RESISTANCE,  
FLOOD RESILIENCE, SOUND INSULATION,  
MINIMUM VIBRATION, DURABILITY,  
ROBUSTNESS, LONG-TERM PERFORMANCE.



[www.uk-bar.org](http://www.uk-bar.org)

## REINFORCE YOUR PROJECT'S SUCCESS

# THE LABOUR AND MATERIALS CRISES: **THE CONTRACTOR PERSPECTIVE**

Concrete contractors are facing up to the new post-pandemic crises: shortages in labour and materials. CONSTRUCT, the Concrete Structures Group, represents almost 80% of RC frame contractors by volume in the UK, and these issues are biting every member reports Dave Campbell, CONSTRUCT Manager.

In a recent survey taken by our members, all of those that responded were facing a labour shortage of some kind, and over half stated that the shortage was acute. In addition to the direct inability to find staff for the roles available, the workforce pool was also demanding higher wage rates, with an average increase of 18-20%, but with extremes of 35%.

The labour shortages are not confined to the skilled labour routes either – general labourers were also in short supply. If we look further up the supply chain, we can see that labour shortages are having an effect there too. The haulage sector – bringing the materials we need to our sites – are also struggling to recruit, which has been causing delivery delays.

Looking at materials, we can also see cost inflation and a general lack of supply. According to the Construction Leadership Council [CLC], demand of construction materials in the first half of the year is up 55%, compared with the same period in 2019. A staple like timber is seeing price increases of 80-100%.

These disruptions to supply chains are not sustainable, and they demand a change in approach. While the acute squeeze on materials is not expected to last more than another six months, the sector needs to readjust the 'just in time' approach, as this will not always be possible. Suppliers of materials need to set expectations, contractors need to plan their materials needs further in advance, and clients also need to take a more flexible approach to contract terms, pricing and schedules.

Tackling the labour shortage is a steep mountain to climb, with the crisis both short and long-term in nature. The pool of labour has significantly reduced with Brexit, and construction cannot rely on highly trained and cheap labour from the rest of the world. Wage inflation may recede slightly, but as the sector is competing with every other part of the UK economy for staff, we should expect wages to rise at a higher rate than pre-Brexit and coronavirus.

*continued overleaf*



CONSTRUCT knows its members' issues are not unique. We are therefore working collaboratively with the rest of the construction industry, and we must work with other sectors of the economy who share common problems that could be resolved by changing government policy.

CONSTRUCT is calling for a flexible and fit-for-purpose immigration system for the long-term that allows the sector to bring in the staff it needs without significant barriers. We also need a short-term solution to help bring in labour temporarily to deal with the current shortages. In the longer-term, we will be working to make the skills system in the UK easier to access, so that we have a new pool of qualified domestic labour.

On materials, CONSTRUCT and its members must have a frank and open conversation with suppliers and their trade bodies about how we manage the supply chain issues now and in the future. CONSTRUCT is proud and excited to have reciprocal membership with the British Association of Reinforcement (BAR) so we can open up dialogue on these, and other issues to the benefit of both sides.



It may be a bumpy road ahead, but working together we will ensure the construction industry continues to prosper and contributes to the rebuilding of the UK economy after a turbulent couple of years.

For information on CONSTRUCT visit:  
<https://construct.org.uk/>



# PRESSING AHEAD AT HINKLEY POINT C

The Hinkley Point C (HPC) nuclear power station is the first nuclear power station to be built in the UK in generation. It is also one of the biggest and most technologically complex projects in Europe.

To meet the demanding performance and logistical challenges, BAR member Dextra has developed Pressed Connection, a headed reinforcement anchor solution (commonly called headed bar) that eliminates the requirement for on-site bending of rebar and so decreases construction time and increases site productivity. The solution enables rebar to be cut and bent via an automatic bending line before being transferred to a fully automated machine for the creation of the head.

The Dextra Pressed Connection solution enables transverse shear reinforcement to be simply dropped into position and tied at the top, eliminating the need for a bottom hooked anchorage. The bar system is being used in the walls and slabs throughout the main civil works at HPC.

The Pressed Connection headed bar has strict CARES approval and a tensile strength performance level whereby the rebar will ultimately break, away from the influence of the head and the connection. This requires ISO 15698 compliance for categories B3 and S (seismic), together with continual production testing of samples during production.

To date, almost 1M Pressed Connection headed bars have been supplied to HPC, together with approximately 1.5M Dextra Griptec rebar coupler and Griptec headed bar components. When complete HPC will provide low-carbon electricity for around six million homes.



*Dextra Pressed Connection headed bar system*



*Dextra Pressed Connection headed bars being used as shear links for the main nuclear island raft*

# AN nVENTFUL PERFORMANCE

The innovative nVent Lenton Taper Threaded System provides a number of benefits over traditional parallel threaded systems. Not least of which are improved product performance, ease of fabrication and more efficient field installation.

Fabrication of parallel threaded systems seems simple in theory, but in practice it is highly variable and prone to error. Inconsistent thread lengths, eccentricity of the thread cross section and variance in rebar deformation shapes can lead to installation and performance issues. A thread defect at a single point along the thread during or after fabrication can render the bar unusable. In contrast, nVent LENTON taper threading equipment produces consistent, high-quality bar ends with minimal changeover and maintenance time. The nVent LENTON machine maintains a consistent thread length using automation, and the conical thread shape is more consistent as it overcomes variation in rebar shape, and minor dings to the thread before installation. Quality is an important factor to any job being done well and can be checked easily with nVent LENTON field gauges.

A key benefit of using nVent LENTON Taper Threaded Systems is the relationship and customer support. Portable threading equipment is provided by nVent at your location, and the equipment maintenance is supported by experienced nVent LENTON service technicians with high quality replacement parts. nVent LENTON is a reputed brand with product and manufacturer approvals and certifications worldwide including CARES, IAPMO, DCL, DIBt, AFCAB and more, promising the highest quality product experience.

When considering installation methods and benefits of the nVent LENTON Taper Threaded Systems, there are a few standout areas:

- Thread is fully engaged in four to five rotations of the coupler
- Taper thread is self-aligning and resistant to cross-threading.
- Slim coupler profile means splice staggering is not required.
- No lock nut needed for non-positional application.
- The axial load capacity of a taper thread is unaffected by over-torquing.



Staying on schedule on a jobsite is important and the self-aligning nVent LENTON tapered thread reduces scaffolding needs and fixing time. Plus, nVent LENTON couplers help reduce labour costs as coupler assembly can be performed in the field by a single worker versus other methods which need two workers. An on-site installation quality inspection can easily take place with a calibrated torque wrench, instead of relying on tightening by hand which can compromise performance and safety.

Ultimately, when choosing which threaded system to use for your project, product performance and quality is key. An important benefit of the nVent LENTON Taper Threaded Systems is that there is no slip in tension or compression, unlike competitors. Slip is defined as the permanent elongation in a splice after loading elastically up to 60 to 70% of specified yield strength of the rebar. A high slip value leads to a high probability of cracking in concrete near the splice under normal loading conditions. A small slip value provides protection against concrete cracking.

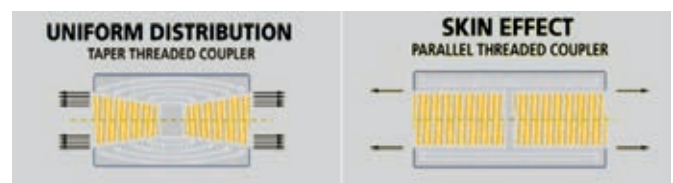

Additionally, the conical thread shape utilizes more of the rebar and coupler cross-section, creating a uniform load distribution and maximizing efficiency. When using parallel threaded systems, the cylindrical thread shape only utilizes the outer layer of rebar material, called skin effect, and leads to inefficient load transfer and stress concentration.

nVent LENTON's product allows high plastic deformation before failure, which means better absorption of fracture energy in catastrophic events. This ensures that the load is more uniformly distributed, and failure is gradual as opposed to sudden, providing more time for occupants to react and reach safety.



# LEADING THE WAY FOR CUSTOMER SERVICE

BRC Reinforcement, ROM Group and Express Reinforcements, the industry-leading suppliers of rebar products to the construction industry, have been developing their own Customer Portals for the past 18 months and are now in a position to launch this for the benefit of all their customers.

The Customer Portals have been developed to be a user-friendly experience for their customers. Once the customer account has been created and administrators assigned, the customer has full control over the account and can provide tailored access to the portal for their own personnel.

Customers are able to view their past, current and proposed deliveries showing the details of all the products being delivered in a friendly calendar or list view.

They can view their historical orders at call-off level, again showing the details of all the products delivered. They are also able to interrogate each delivery and each order to bar mark level and then further to show the mechanical and chemical properties of the rebar and if they wish, can obtain a copy of the Test Certificate associated to this bar mark.

Perhaps one of the most impressive parts is that each delivery displays the total amount of CO<sub>2</sub> generated to deliver this material to site. This CO<sub>2</sub> figure is calculated to include the lifecycle of the product. This includes the delivery of the scrap to the steel mill, the melting of this scrap into billet, the production of this billet into bar or coil, the delivery to BRC, Express or ROMs manufacturing facilities and also the processing of this raw material into finished product and finally the CO<sub>2</sub> generated to deliver the material to site.

The Customer Portal will also allow you to retrieve your Proof of Delivery documents and download various list into excel for you to use.

The businesses will be further enhancing the functionalities within the Customer Portal, based on the feedback and future requirements of their customers.

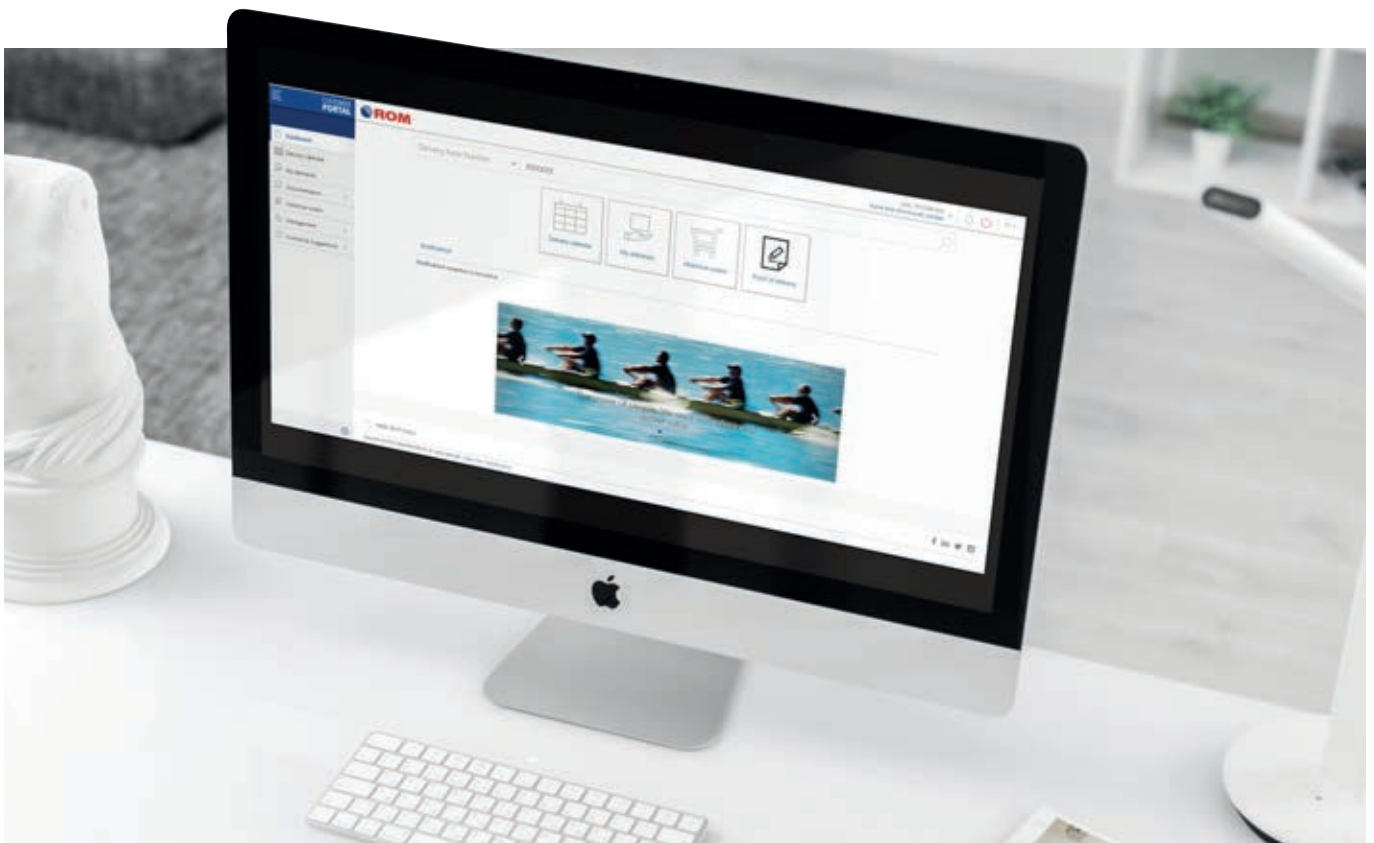

# DELIVERING REINFORCED TRUST

Trust is a simple concept that is fundamental to successful business relationships. There must be trust that a service or product meets the right standards and delivers the necessary quality.

When it comes to trust, all members of the British Association of Reinforcement (BAR) are committed to ensuring that their customers can have the utmost trust in the steel reinforcement products and services being provided.

## DELIVERING A QUALITY PRODUCT

All BAR reinforcement manufacturer, fabricator and accessory supplier members ensure that the products that they offer meet and conform to all relevant UK and international standards. In addition, BAR members sit on industry committees to provide expertise for standards review and development.

Furthermore, all BAR members are fully signed-up to recognised industry certification schemes. Their accreditation provides external recognition of consistent product quality and adherence to standards that is underlined by regular, independent auditing.

## DELIVERING A SUSTAINABLE PRODUCT

All BAR members are committed to reducing their environmental impact and increasing their sustainability credentials. Reinforcement steel is produced using recycled steel via the Electric Arc Furnace (EAF) method, giving a 98% recycled content to the finished product. Producing steel by this method can reduce its carbon footprint by nearly four times when compared to the Basic Oxygen Steelmaking (BOS) process. All members are actively addressing key issues such as waste management, recycling, reduction of water and energy usage and reduction of transport emissions.

The commitment of BAR members to ongoing environmental improvement is underlined by their accreditation to recognised sustainable certification schemes such as EcoReinforcement, the CARES Sustainable Construction Steels scheme and standards such as BES6001 and ISO14001.

## DELIVERING A RESPONSIBLY SOURCED PRODUCT

Responsible sourcing is an important consideration for BAR members who have all adopted this approach to their sourcing and supply chains. Each of them actively and consciously source materials and products in an ethical, sustainable and socially conscious way.



In addition, BAR members are fully signed-up to comprehensive health and safety programmes, anti-human slavery and equality policies, and the implementation of robust supply chain traceability and corporate accountability.

## DELIVERING SOCIAL VALUE

BAR members have active programmes of community and schools engagement, employment for people with previous convictions, work with national and local charities and investment in their local economies. They are fully signed up to deliver social value and play an active positive role of involvement in their local community. Customers of BAR members can trust that their reinforcement supplier will enable meeting the objectives of the Social Value Act 2013 and delivering social value and positive outcomes through construction.

## DELIVERING TRUST

The members of BAR are listed overleaf. All are committed to delivering steel reinforcement products and services that you can trust.

# RAISING THE BAR



[www.uk-bar.org](http://www.uk-bar.org)

BAR members are fully supportive of the Association's objectives aimed at raising the bar for the UK reinforcement sector by:

- Providing a forum in which common issues facing the UK reinforcement industry can be addressed.
- Forwarding and supporting the market share of reinforced concrete against competitive structural materials.
- The Association cannot dictate material sourcing but expects its members to, wherever possible, to forward and support the UK steel and reinforcement sectors.
- Enhancing and forwarding overall product and service quality provided by BAR members
- Improving the health and safety record of the UK reinforcement industry.
- Improving the environmental record of the UK reinforcement industry.
- Actively promoting the UK reinforcement industry's products and capabilities to relevant target audiences.
- Representing the UK reinforcement industry with HM Government, in Europe and with other decision makers.

## BAR Members' Directory

### Arcelor Mittal Kent Wire

Chatham Docks  
Chatham  
Kent ME4 4SR  
Tel: 01634 823604  
Email: [sales@arcelormittalkentwire.co.uk](mailto:sales@arcelormittalkentwire.co.uk)  
Web: [www.arcelormittalkentwire.co.uk](http://www.arcelormittalkentwire.co.uk)

### BRC Ltd

Corporation Road  
Newport  
South Wales NP19 4RD  
Tel: 01633 280816  
Email: [enquiries@brc.ltd.uk](mailto:enquiries@brc.ltd.uk)  
Web: [www.brc.ltd.uk](http://www.brc.ltd.uk)

### Celsa Steel (UK) Limited

Building 58  
East Moors Road  
Cardiff CF24 5nn  
Tel: 029 2035 1800  
Email: [general@celsauk.com](mailto:general@celsauk.com)  
Web: [www.celsauk.com](http://www.celsauk.com)

### CONSTRUCT - Concrete Structures Group

The Building Centre  
26 Store Street  
London  
WC1E 7BT  
Tel: 0844 249 1355  
Email: [enquiries@construct.org.uk](mailto:enquiries@construct.org.uk)  
Web: [www.construct.org.uk](http://www.construct.org.uk)

### Dextra Manufacturing - UK

34A Ryegate Road  
Sheffield S10 5TB  
Tel: 0114 3211868  
Email: [rgoodman@dextragroup.com](mailto:rgoodman@dextragroup.com)  
Web: [www.dextragroup.com](http://www.dextragroup.com)

### ERICO Europa (GB) Ltd

20-22 Bedford Row  
London WC1R 4JS  
Tel: 07887 764 210  
Email: [mallen@erico.com](mailto:mallen@erico.com)  
Web: [www.erico.com](http://www.erico.com)

### Express Reinforcements Ltd

Eaglebush Works  
Milland Road  
Neath  
Wales SA11 1NJ  
Tel: 01639 645555  
Fax: 01639 645558  
Email: [commercial@expressreinforcements.co.uk](mailto:commercial@expressreinforcements.co.uk)  
Web: [www.expressreinforcements.co.uk](http://www.expressreinforcements.co.uk)

### Max Frank Ltd

Whittle Road  
Meir  
Stoke-on-Trent  
Staffordshire  
ST3 7HF  
Email: [info@maxfrank.co.uk](mailto:info@maxfrank.co.uk)  
Website: [www.maxfrank.co.uk](http://www.maxfrank.co.uk)

### Outokumpu Stainless Steel Limited

PO Box 161  
Sheffield  
South Yorkshire S9 1ZT  
Tel: 0114 261 5234  
Email: [sales.rebar@outokumpu.com](mailto:sales.rebar@outokumpu.com)  
Web: [www.outokumpu.com](http://www.outokumpu.com)

### RFA-Tech

C/O ROM Building  
Eastern Avenue  
Trent Valley  
Lichfield WS13 6RN  
Tel: 0870 011 2881  
Email: [sales@rfa-tech.co.uk](mailto:sales@rfa-tech.co.uk)  
Web: [www.rfa-tech.co.uk](http://www.rfa-tech.co.uk)

### ROM Limited

Eastern Avenue  
Trent Valley  
Lichfield  
Staffordshire WS13 6RN  
Tel: 0870 011 3601  
Fax: 01543 421657  
Email: [sales@rom.co.uk](mailto:sales@rom.co.uk)  
Web: [www.rom.co.uk](http://www.rom.co.uk)

### ROM-Tech

Unit 16  
Eastern Avenue  
Trent Valley  
Lichfield  
Staffordshire WS13 6RN  
Tel: 0870 011 3610  
Web: [www.rom-tech.co.uk](http://www.rom-tech.co.uk)

# REINFORCE

2021



[www.uk-bar.org](http://www.uk-bar.org)